



Engine and Alternator

Engine	Perkins 403D-11G
Output Rating	8 KVA
Engine Speed	1500 rpm
Engine Type	Liquid cooled diesel engine
Number of Cylinders	3
Alternator	Meccalte LT3N-160, 4 pole
Voltage	220 V
Controller	Basic Analogue

900 kg Manual Winch

Model	RBW2000
Treatment	Hot-galvanization
Maximum load	908 kg
Traction	Rotate in clockwise direction
Release	Rotate in counterclockwise direction

Floodlights

Lamp	Metal halide
Power	4x1000 W
Illuminated area	3800 m ²
Degree of protection	IP 54
Constructor material of the body	Printed aluminium
Constructor material of lamp holder	Ceramic
Reflector	Printed aluminium
Cable gland	Stainless steel
Optical case opening system	Screw and lock nut
Dimensions (L x H x D mm)	580 x 560 x 220

ILLUMINATED AREA: 4000 m²

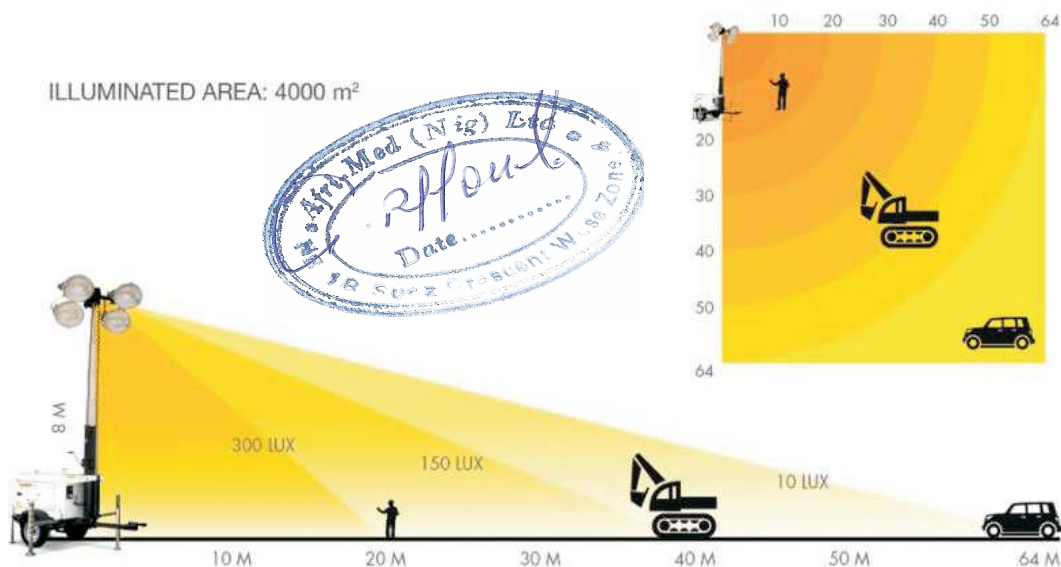

All information in this document is substantially correct at the time of printing and may be altered subsequently.

Marapco Ltd

8 Meadowbank Rd - Carrickfergus - N. Ireland - U.K. BT38 8YF
 Tel: +44 (0) 2893 355674 - www.marapco.com - Email: sales@marapco.com



Distributed & Serviced by:



LIGHT TOWER MPLT8

Marapco Light Towers offer complete lighting solutions for a wide array of applications and are tested under harsh conditions to withstand the rough environments common on different sites. Marapco Light Towers combine quality and performance to deliver a superior product, making it a market leading lighting tower throughout the Middle East, Asia & Africa.

Lighting Tower

Maximum height	8 mt
Raising	Manual
Section	7
Rotation Section	340°
Electrical coiled cable	9G2,5 mmq
Electrical cable of floodlights	H07RN-F
Maximum wind stability	80 km/h
Minimum dimension (L x W x H mm)	2860 x 1270 x 2570
Maximum dimension (L x W x H mm)	2860 x 2440 x 8000
Weight with dray	756 kg
Lifting Point	Single at top
Sound Pressure Level	67dBA @ 7m
Fuel Tank Capacity	75 Liters
Fuel Consumption	1.7 L/hour
Continous Running Hours	44
Body Type	Metal

Raising and Lowering Rope

Rope type	AZN625APPCOM
Rope diameter	6 mm
Outer wires diameter	0,4 mm
Weight per meter	0,15 Kg
Construction	6x(12+(6)+6+1)KF+PP
Type of lay	Right hand ordinary lay
Tensile strength	2160 N/mm ²
Strands	Compacted
Preformed	Yes
Steel wires	Carbon
Protection of wire rope	Galvanized class B
Minimum breaking load	32,3 kN 3230 Dan 3294 Kg

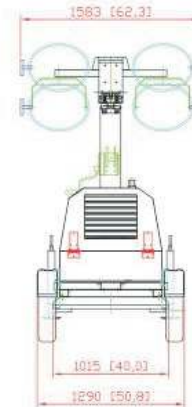
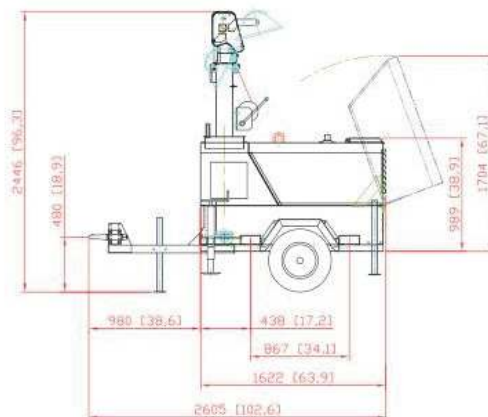

All information in this document is substantially correct at the time of printing and may be altered subsequently.

Marapco Ltd

8 Meadowbank Rd - Carrickfergus - N. Ireland - U.K. BT38 8YF
 Tel: +44 (0) 2893 355674 - www.marapco.com - Email: sales@marapco.com



Distributed & Serviced by: